

Centrifugal fan model TF, Es.4

Single inlet fan, direct driven with an IEC-standard motor in form B3 which is mounted on a motorbase. The overhang impeller is mounted on the motor shaft and has backwardly curved blades. The blades are welded between the back plate disc and the aerodynamically formed front plate. The robust industrial fan is totally made of steel and painted in the agate grey color RAL 7038. The fan is suitable for the transport of granules and trimmings in nylon; for loading solid fuels into boilers, etc.

General data:

Drive	direct	
Motor position	horizontal	
Material casing/base	Steel	
Material impeller/hub	Steel	
Coating/protection	RAL 7038	
Operating temperature (max.)	15 (80)	°C
Medium density (altitude 0 m)	1,226	kg/m ³
Impeller speed	2.930	rpm
Weight	129	kg
Sound pressure level ±3 (at 1,5 m near the fan with inlet and outlet ducted, in free field)	86	dB(A)

Electric motor:

	132S	IEC
Power	5,5	kW
Motor speed	2.930	rpm
Electric supply	3x400V50Hz	V/Hz
Full load current	10,60	A
Enclosure	55	IP
Shape	B3T	
Efficiency class	IE3	

Curve TG 501B @ 2930rpm @ 15°C @ 0m

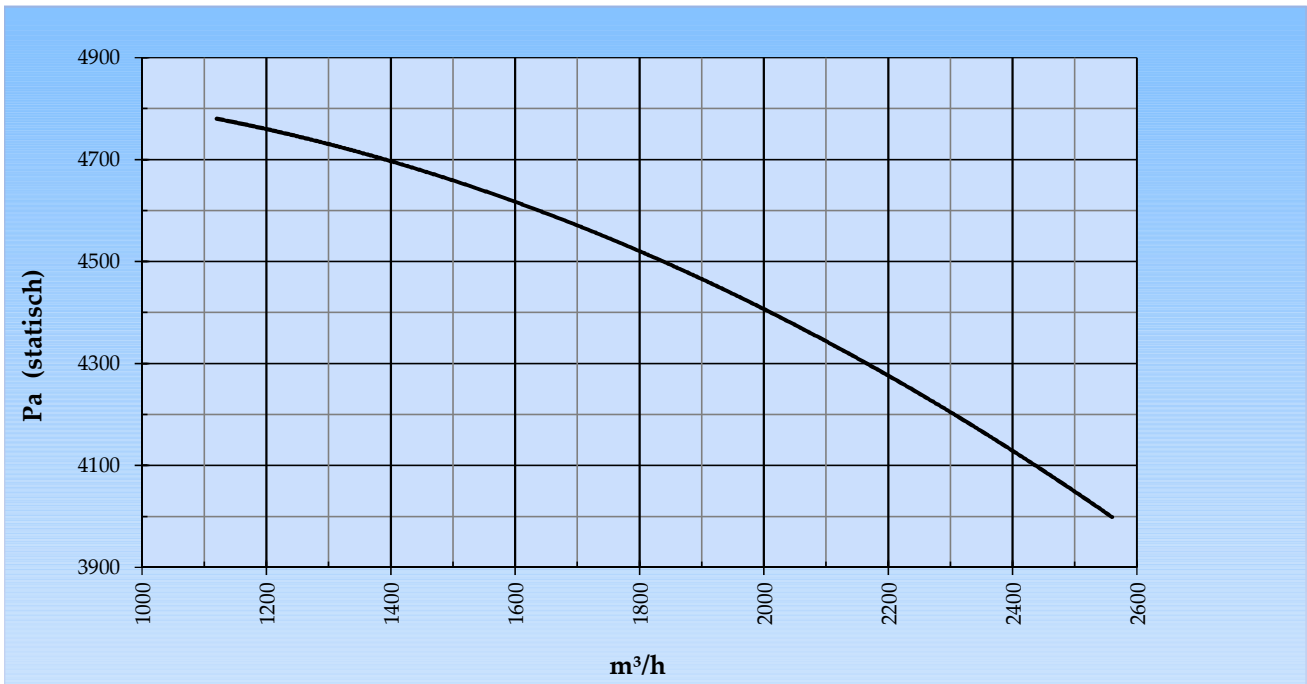

Possible discharge positions:

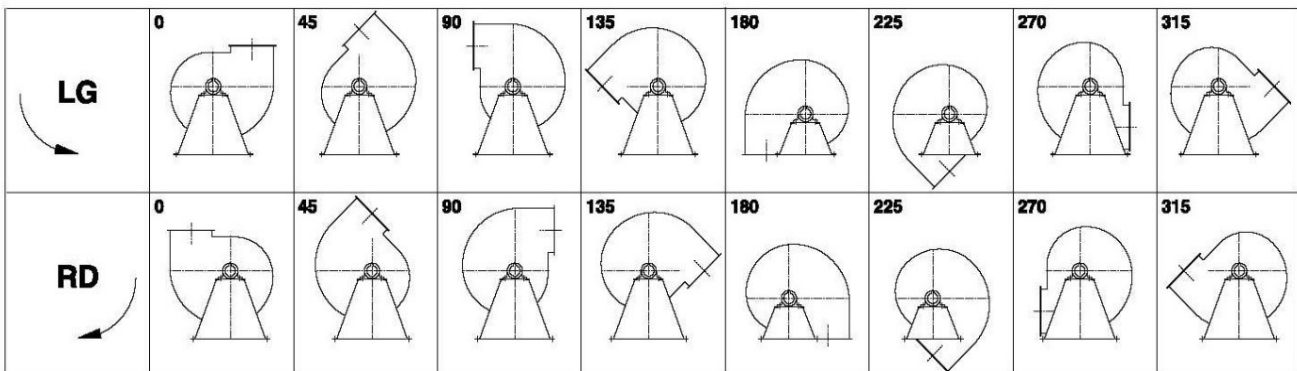

* (Pos 180 and 225 extra price)

Possible accessories

Mounting profiles for load distribution	AP13201ST
Counterflange inlet/outlet	
Flexible connection inlet/outlet max. 80°C	zzØ 205 / pz 180x125
Anti-vibration mountings	4x 40x30/B/70° ShA
Inspectiondoor	
Drain	
Shaft seal without asbestos	
Coolingwheel (medium max. 150°C)	(incl. coating RAL9006)
Flexible connection inlet/outlet max. 150°C	zzØ 205 / pz 180x125
ATEX version	Zone 1 / 2 / 21 / 22
ATEX motor	Ex nA / Exe / Ex de
Coating suitable for outdoor application	RAL 5010 / RAL
Stainless steel version	304 / 316 / ...
Acoustic enclosure	

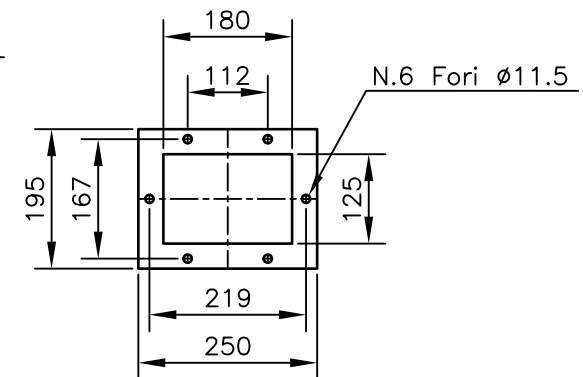
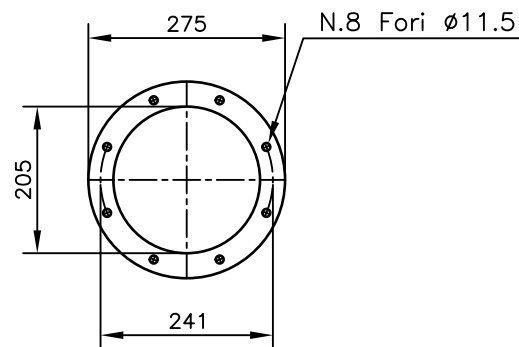
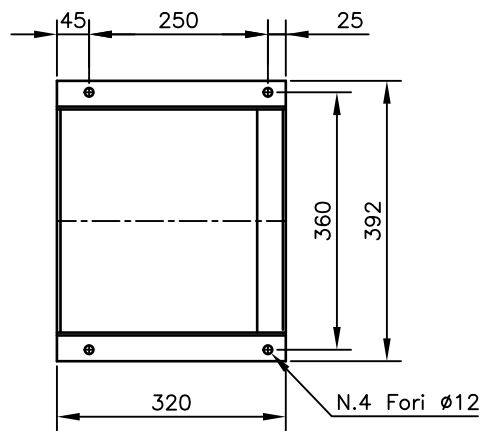
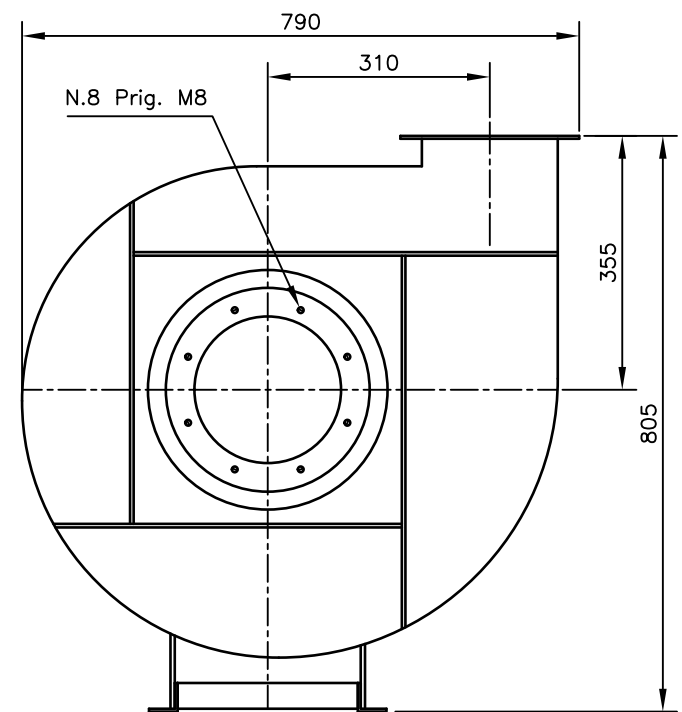
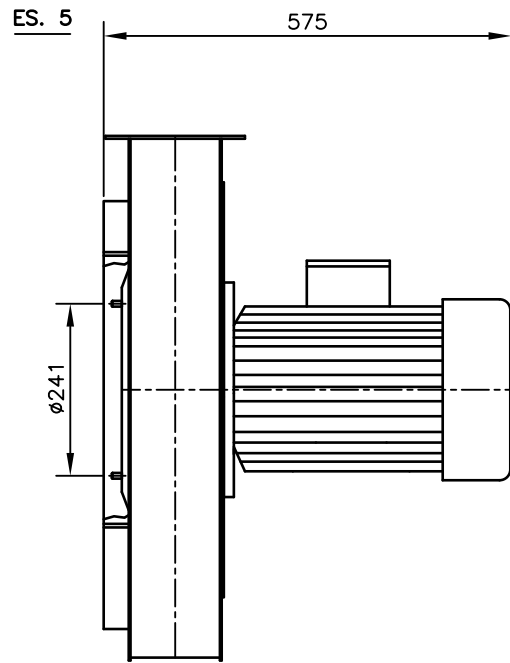
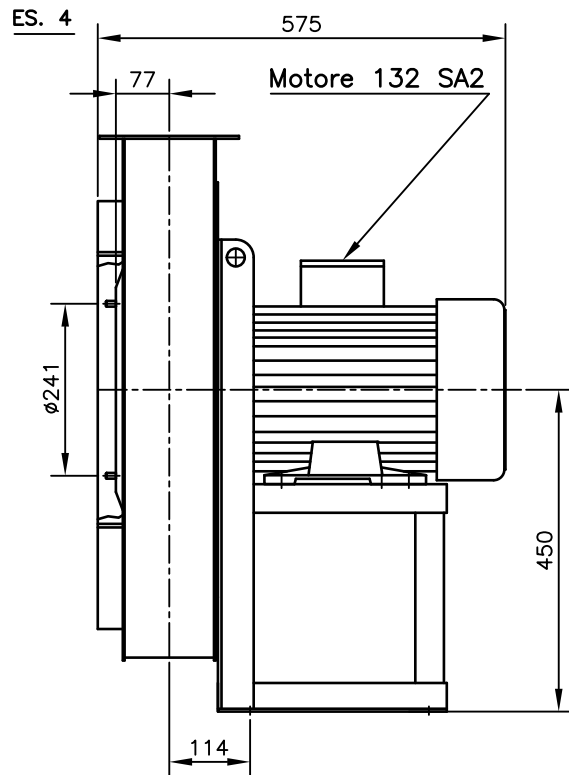

DESCRIZIONE TG 501-B RDO Es. 4-5 Mot. 132 SA2	SCALA: 1:10	PESO: kg .	FORMATO: A4
	DATA: .	DISEGNATO: .	
Copy 8-9-2020			

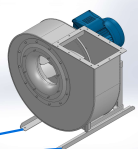
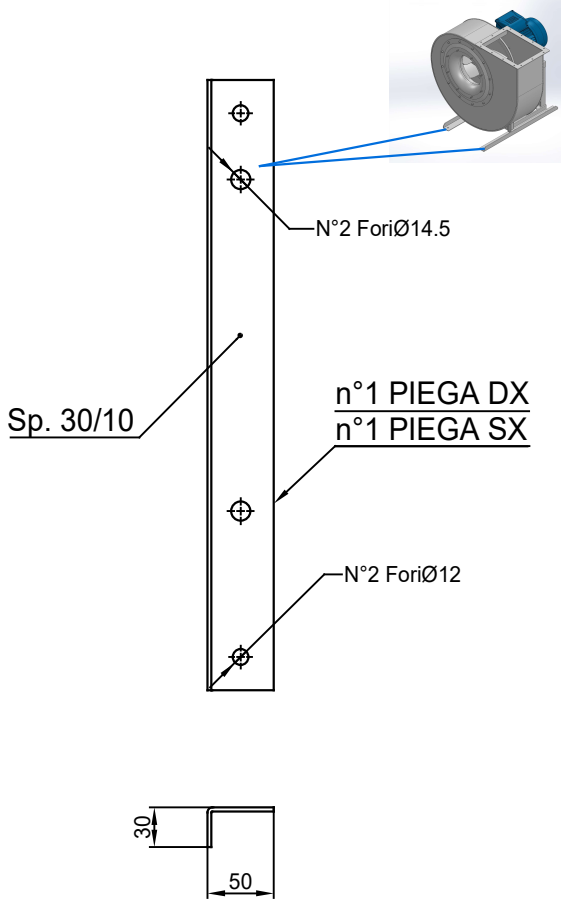
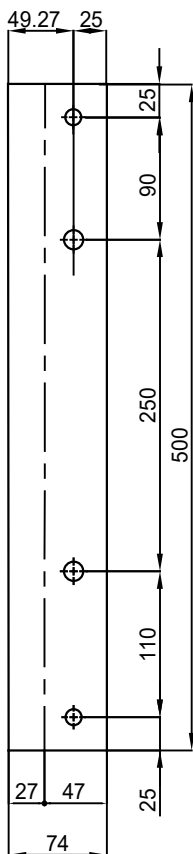

COMM.
N°

00	02/02/2016	PRIMA EMISSIONE		RK	RK
01	16/09/2020	Extension pedestal		MvS	MvS
REV	DATA - DATE	DESCRIZIONE - DESCRIPTION		DISEGNATO PREPARED	CONTROLLATO CHECKED
DESCRIZIONE - DESCRIPTION		MATERIALE - MATERIAL	NR. FILE	PESO - WEIGHT	
DESCRIZIONE - DESCRIPTION		Fe 360		Kg	
Staffe per Puffer L=500 IEC 132 / AP series			SCALA 1:4	DISEGNATO - PREPARED	FORMATO
			DATA 02/02/2016	RK	A4
			SOSTITUISCE IL - REPLACES THE N° SOSTITUITO DAL - REPLACES BY N°		
N. DISEGNO - N. DRAWING			Slingerland ventilatoren		REV.
STF-AP13201ST					01