

Centrifugal fan model APRF, Es.4

Single inlet fan, direct driven with an IEC-standard motor in form B3 which is mounted on a motorbase. This series of high-pressure fans is characterized by a high efficiency with electricity saving by installing a special impeller with backward curved blades. The robust industrial fan is totally made of steel and painted in the agate gray RAL 7038. The fan is suitable for the transportation of clean and slightly dusty air.

General data:

Drive	direct	
Motor position	horizontal	
Material casing/base	Steel	
Material impeller/hub	Steel	
Coating/protection	RAL 7038	
Operating temperature (max.)	15 (80)	°C
Medium density (altitude 0 m)	1,226	kg/m ³
Impeller speed	2.935	rpm
Weight	200	kg
Sound pressure level ±3 (at 1,5 m near the fan with inlet and outlet ducted, in free field)	83	dB(A)

Electric motor:

	132M	IEC
Power	9,2	kW
Motor speed	2.935	rpm
Electric supply	3x400V50Hz	V/Hz
Full load current	16,6	A
Enclosure	55	IP
Shape	B3T	
Efficiency class	IE3	

Curve APRF 711B @ 2935rpm @ 15°C @ 0m

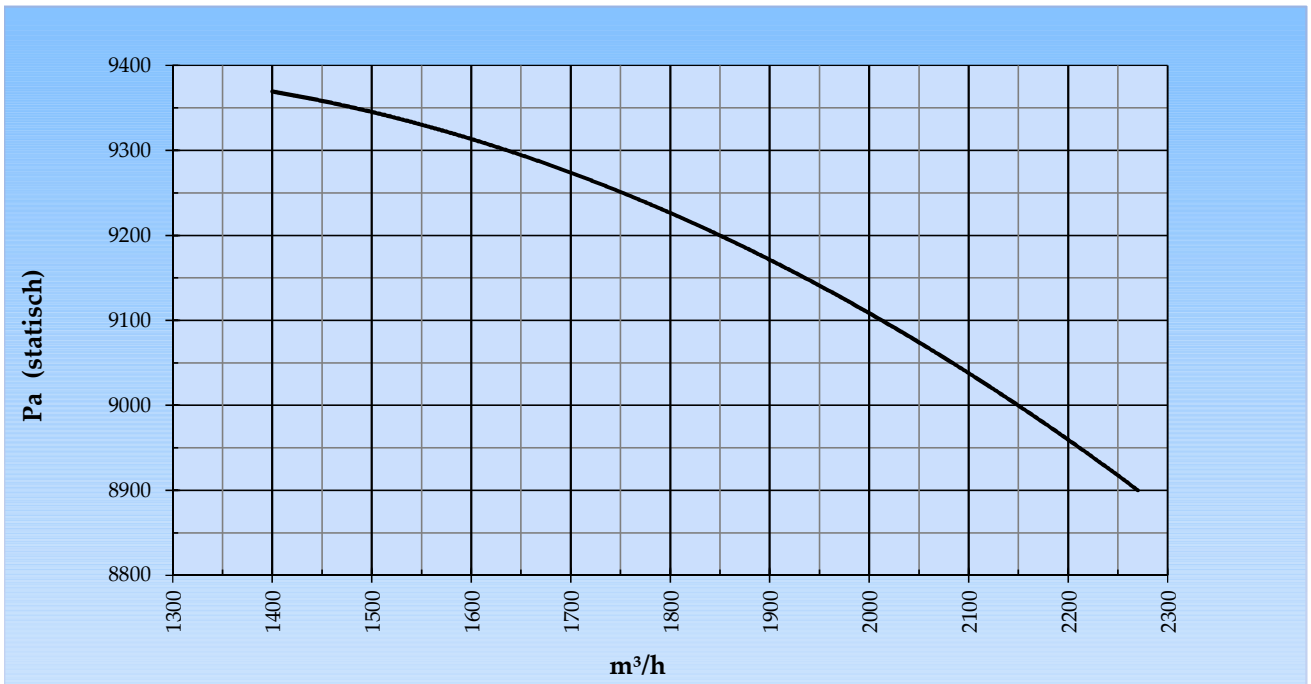

Possible discharge positions:

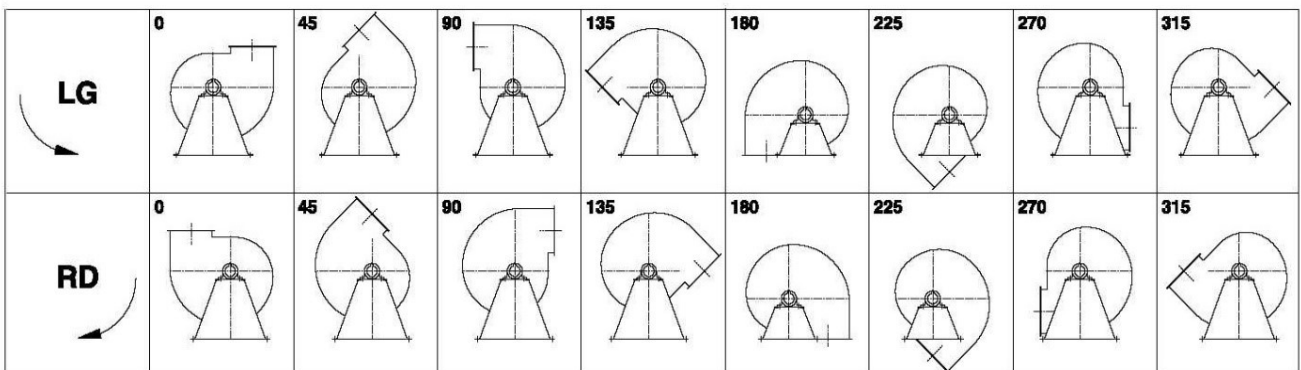

* (Pos 180 en 225 tegen meerprijs)

Possible accessories

Mounting profiles for load distribution	AP13201ST
Counterflange inlet/outlet	
Flexible connection inlet/outlet max. 80°C	zzØ 229 / pz 180x125
Anti-vibration mountings	4x 40x30/B/70° ShA
Inspectiondoor	
Drain connection	
Shaft seal without asbestos	
Coolingwheel (medium max. 150°C)	(incl. coating RAL9006)
Flexible connection inlet/outlet max. 150°C	zzØ 229 / pz 180x125
ATEX version	Zone 1 / 2 / 21 / 22
ATEX motor	Ex nA / Exe / Ex de
Coating suitable for outdoor application	RAL 5010 / RAL ...
Stainless steel version	304 / 316 / ...
Acoustic enclosure	

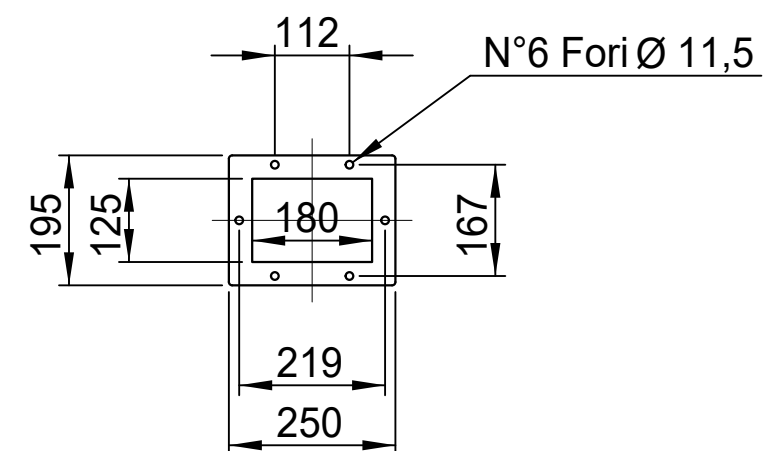
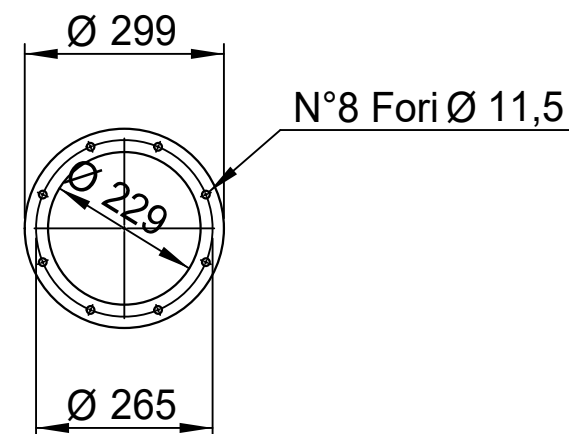
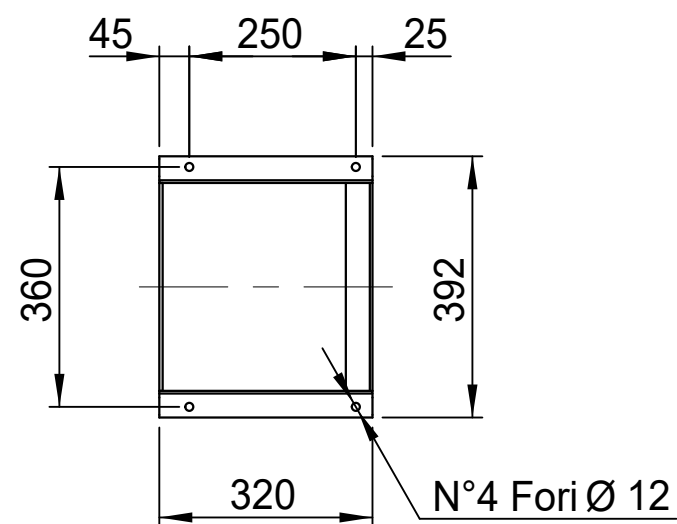
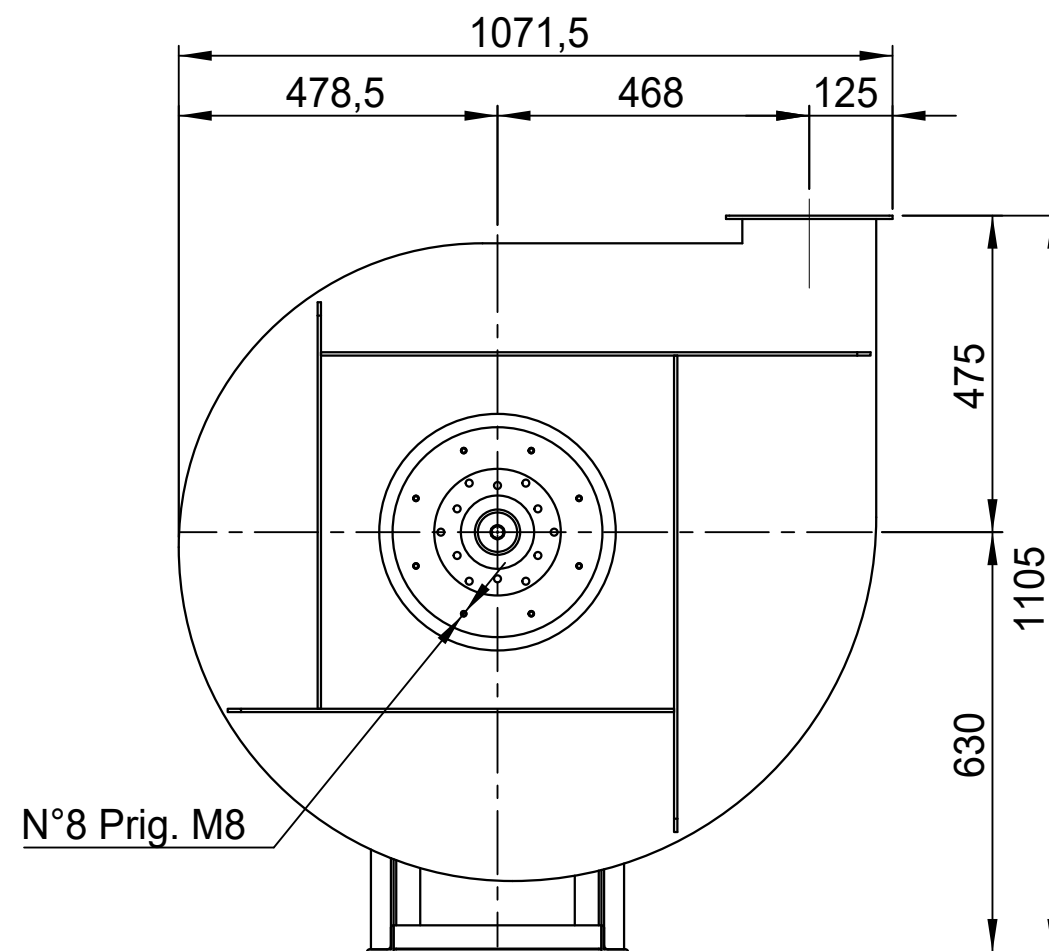
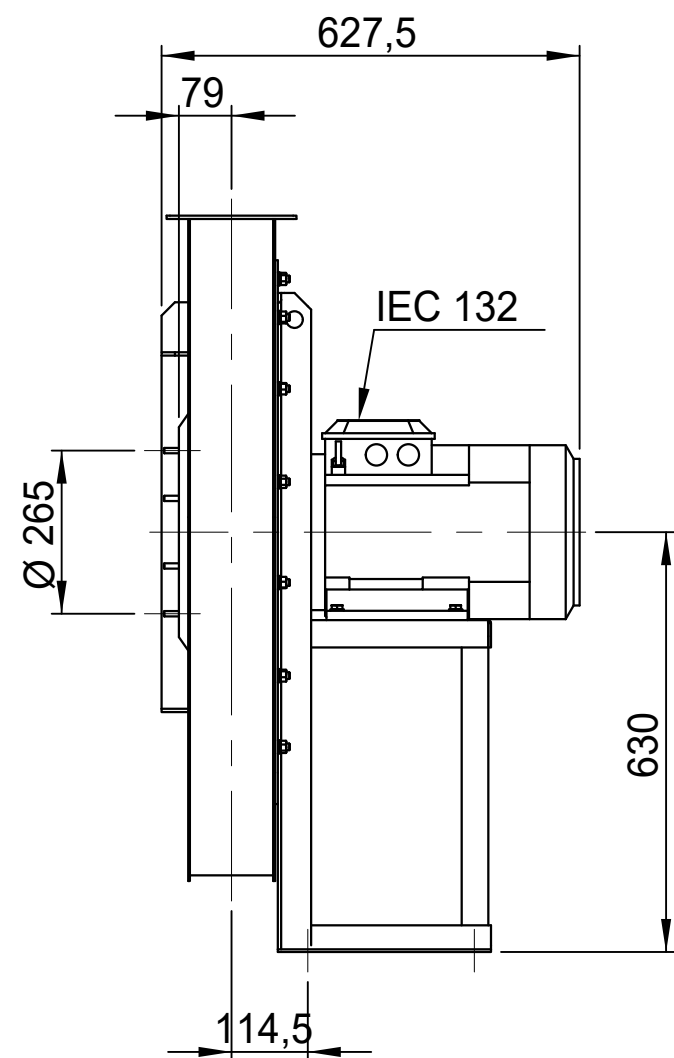

APRF 711/B - RD 0

SCALA 1:15

FORMATO

DATA 20/02/2015

A4

SOSTITUISCE IL - REPLACES THE N° APRF711A411B000

SOSTITUITO DAL - REPLACES BY N°

REV.

Copy 7-2-2020

Slingerland
ventilatoren



00

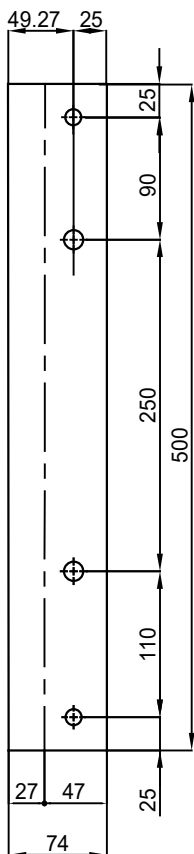

Sp. 30/10



n°1 PIEGA DX
n°1 PIEGA SX

N°2 ForiØ14.5

N°2 ForiØ12

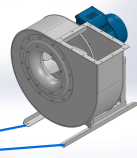

COMM.
N°

00	02/02/2016	PRIMA EMISSIONE		RK	RK
01	16/09/2020	Extension pedestal		MvS	MvS
REV	DATA - DATE	DESCRIZIONE - DESCRIPTION		DISEGNATO PREPARED	CONTROLLATO CHECKED
DESCRIZIONE - DESCRIPTION		MATERIALE - MATERIAL	NR. FILE	PESO - WEIGHT	
DESCRIZIONE - DESCRIPTION		Fe 360		Kg	
Staffe per Puffer L=500 IEC 132 / AP series			SCALA 1:4	DISEGNATO - PREPARED	FORMATO
			DATA 02/02/2016	RK	A4
			SOSTITUISCE IL - REPLACES THE N° SOSTITUITO DAL - REPLACES BY N°		
N. DISEGNO - N. DRAWING				REV.	
STF-AP13201ST				01	

