

## TG 561A

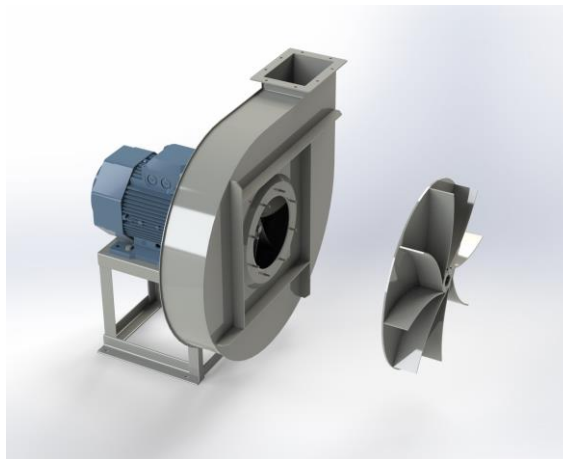

### Centrifugal fan model TG, Es.4

Single inlet fan, direct driven with an IEC-standard motor in form B3 which is mounted on a motorbase. The overhang impeller is mounted on the motor shaft and has backwardly curved blades. The blades are welded between the back plate disc and the aerodynamically formed front plate. The robust industrial fan is totally made of steel and painted in the agate grey color RAL 7037. The fan is suitable for the transport of granules and trimmings in nylon; for loading solid fuels into boilers, etc.

#### General data:

Drive	direct
Motor position	horizontal
Material casing/base	Steel
Material impeller/hub	Steel
Motorcoating/protection	RAL 7037
Operating temperature (max.)	15 (80) °C
Medium density (altitude 0 m)	1,226 kg/m <sup>3</sup>
Impeller speed	2930 rpm
Weight	144 kg
Sound pressure level ±3	89 dB(A)

*(at 1,5 m near the fan with inlet and outlet ducted, in free field)*

#### Electric motor:

	132S	IEC
Power	7,5	kW
Motor speed	2.930	rpm
Electric supply	3x400V50Hz	V/Hz
Full load current	14,1	A
Enclosure	55	IP
Shape	B3T	
Efficiency class	IE3	

Curve TG 561A @ 2930rpm @ 15°C @ 0m

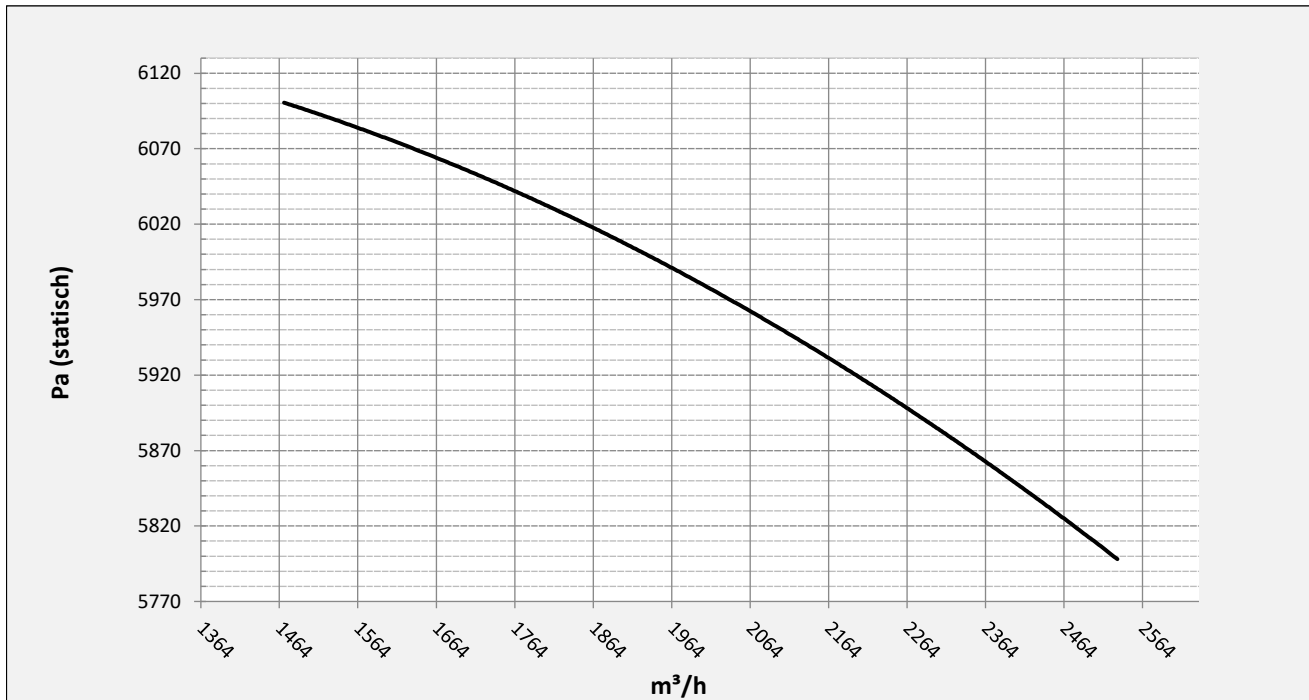

Possible discharge positions:

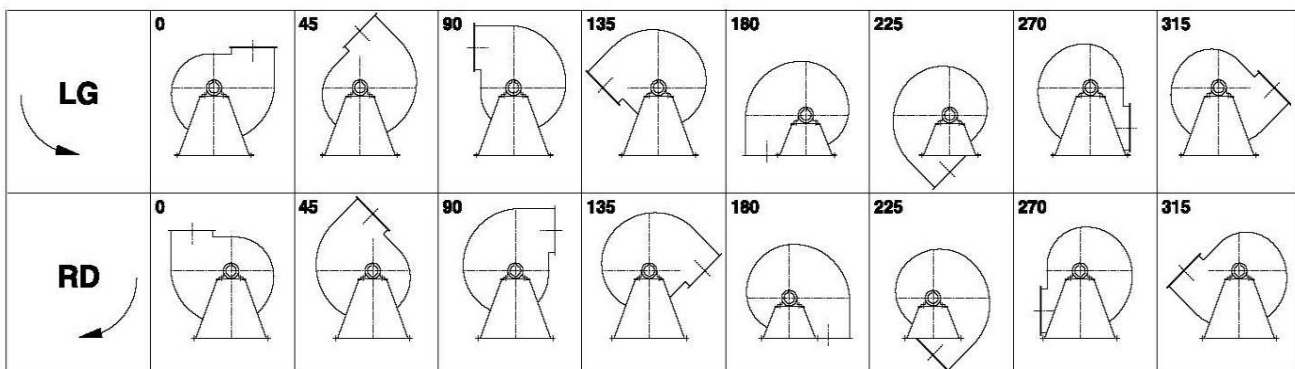

\* (Pos 180 and 225 extra price)

Possible accessories

Mounting profiles for load distribution	AP13201ST
Counterflange inlet/outlet	zz Ø224 / pz 200x140
Flexible connection inlet/outlet max. 80°C	zz Ø250 / pz Ø250
Anti-vibration mountings	4x 40x30/B/70° ShA
Inspection door	
Drain connection	
Shaft seal without asbestos	
Coolingwheel (medium max. 150°C)	( incl. coating RAL9006 )
Flexible connection inlet/outlet max. 150°C	zz Ø250 / pz Ø250
ATEX version	Zone 1 / 2 / 21 / 22
ATEX motor	Ex nA / Exe / Ex de
Coating suitable for outdoor application	RAL 5010 / RAL ....
Stainless steel version	304 / 316 / ...
Acoustic enclosure	

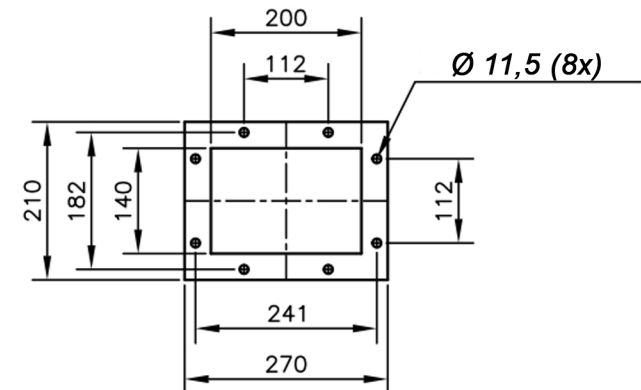
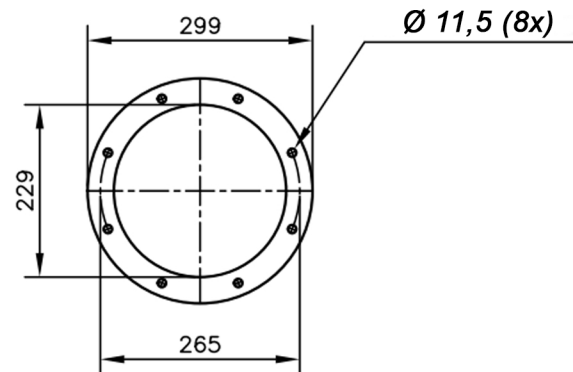
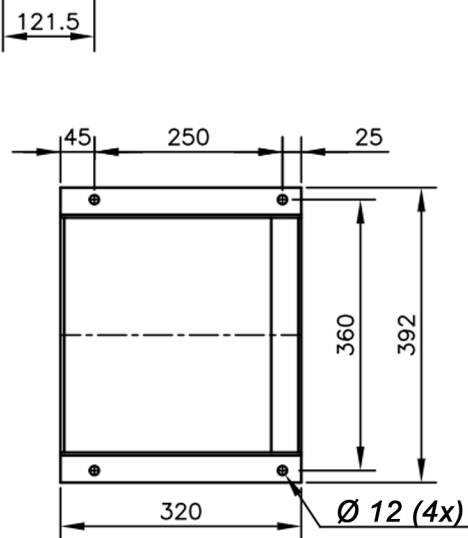
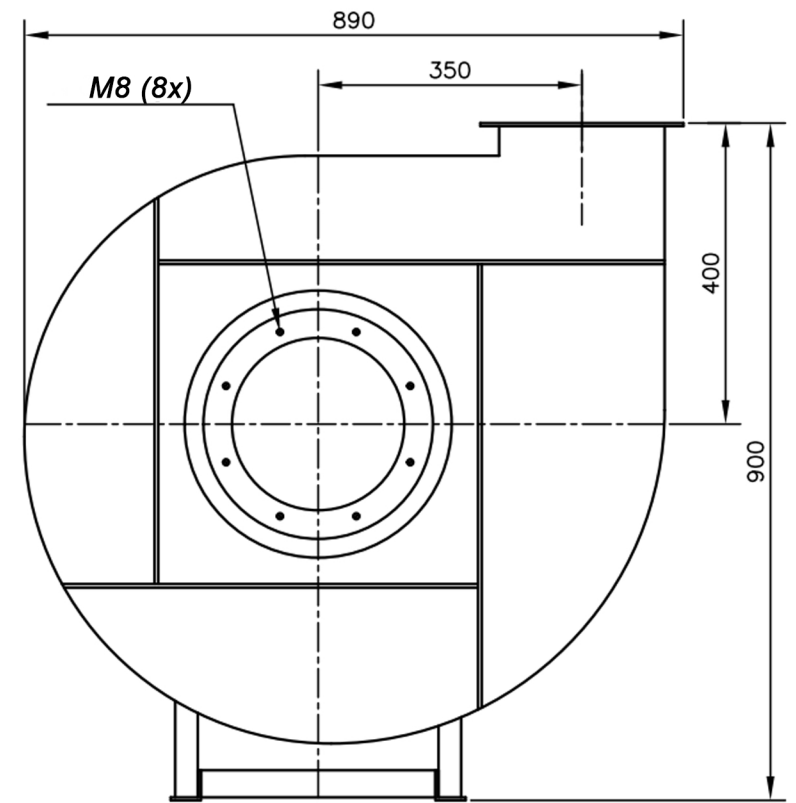
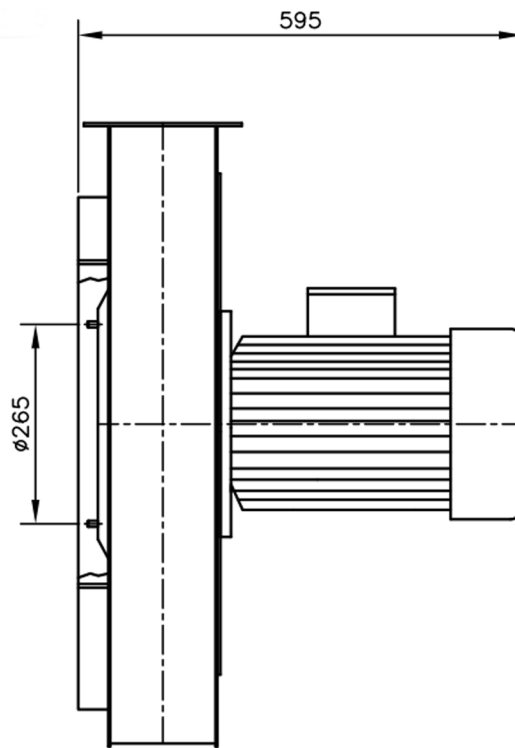
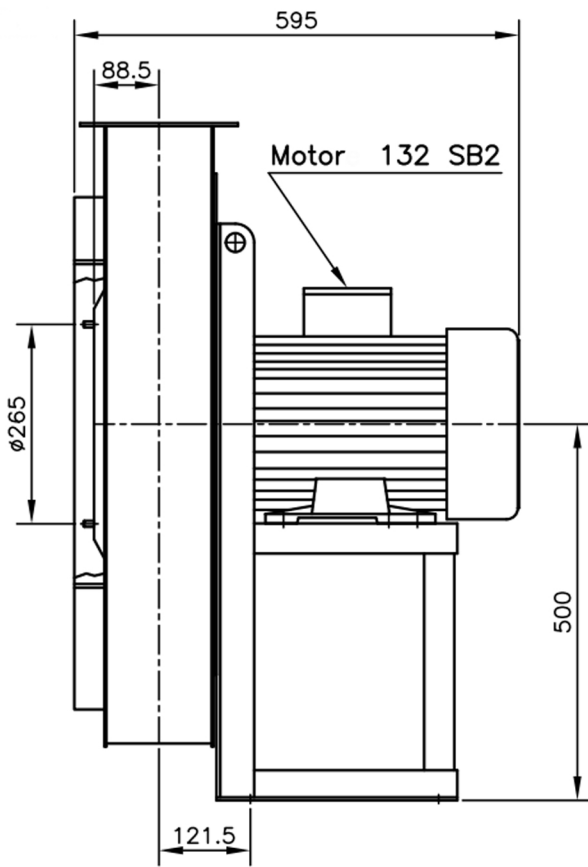

DESCRIPTION-BESCHRIJVING	SCHAAL	GEMAAKT - PREPARED	FORMAAT
<b>TG561/A - RD0</b>	<b>1:10</b>	<b>Overmeer E.</b>	<b>A4</b>
	DATUM		
	<b>29/11/2023</b>		
N.TEKENING - N.DRAWING		REV.	
		<b>V1TG561/A</b>	
		<b>00</b>	

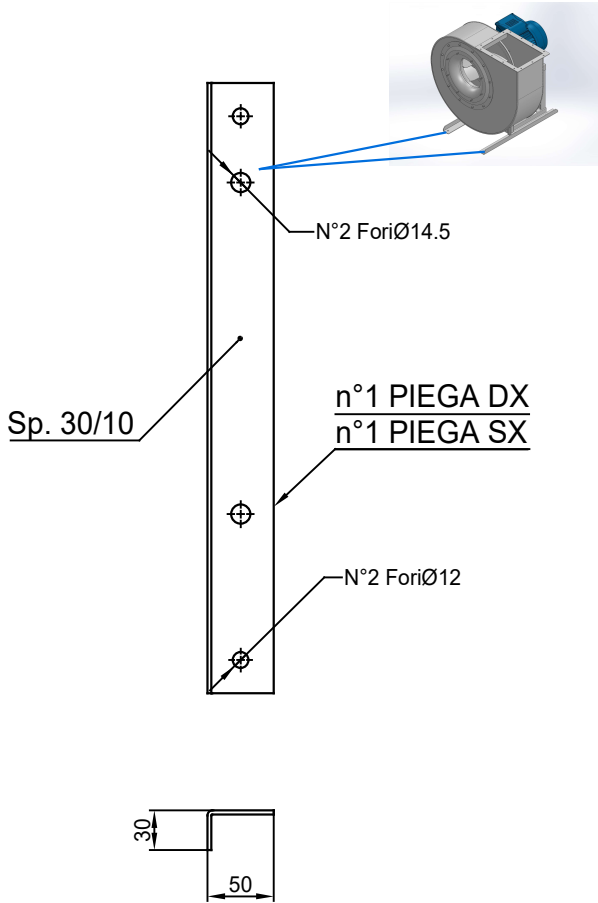
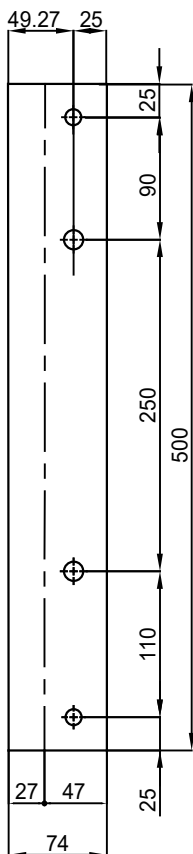

COMM.  
N°

00	02/02/2016	PRIMA EMISSIONE		RK	RK	
01	16/09/2020	Extension pedestal		MvS	MvS	
REV	DATA - DATE	DESCRIZIONE - DESCRIPTION		DISEGNATO PREPARED	CONTROLLATO CHECKED	
DESCRIZIONE - DESCRIPTION			MATERIALE - MATERIAL	NR. FILE	PESO - WEIGHT	
DESCRIZIONE - DESCRIPTION			Fe 360		Kg	
Staffe per Puffer L=500 IEC 132 / AP series			SCALA	1.4	DISEGNATO - PREPARED	FORMATO
			DATA	02/02/2016	RK	A4
			SOSTITUISCE IL - REPLACES THE N°			
			SOSTITUITO DAL - REPLACES BY N°			
N. DISEGNO - N. DRAWING				REV.		
STF-AP13201ST				Slingerland ventilatoren		
				01		